

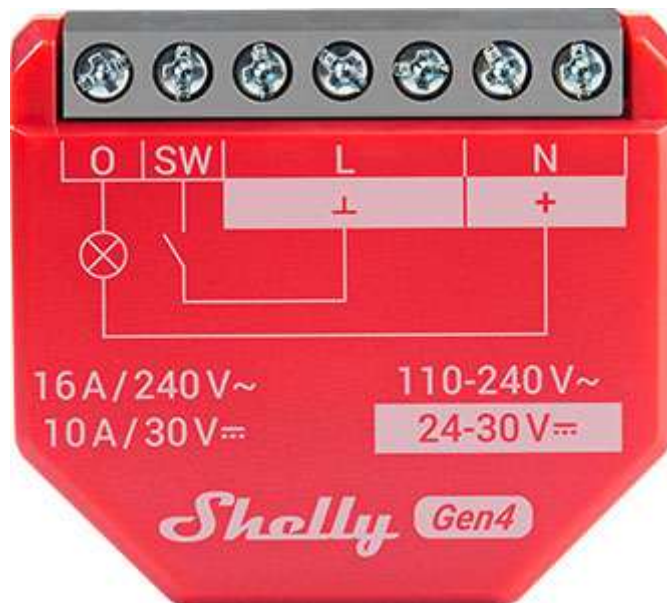

Shelly 1PM Gen4 datasheet

Shelly 1PM Gen4



Device identification

- Device name: **Shelly 1PM Gen4**
- Device model: **S4SW-001P16EU**
- Device SSID: **Shelly1PMG4-XXXXXXXXXXXX**
- Device Bluetooth ID: **0x1029**

Short description

Shelly 1PM Gen4 is a small form factor smart switch with power measurement, which allows remote control of electric appliances through a mobile phone, tablet, PC, or home automation system. It can work standalone in a local Wi-Fi network or it can also be operated through cloud home automation services.

Shelly 1PM Gen4 can be accessed, controlled and monitored remotely from any place where the User has internet connectivity, as long as the device is connected to a Wi-Fi router and the Internet.

It can be retrofitted into standard electrical wall boxes, behind power sockets and light switches or other places with limited space.

Shelly 1PM Gen4 has embedded Web Interface which can be used to monitor and control the device, as well as adjust its settings.

The device has multi-protocol wireless MCU which provide Zigbee and Bluetooth connectivity ensuring a secure connection.

This device is compatible with Matter.

Main features



Shelly 1PM Gen4 datasheet

- **Wi-Fi Connectivity:** The device can connect to your home Wi-Fi network, allowing you to remotely monitor humidity and temperature data through a smartphone app or other compatible devices.
- **Bluetooth Connectivity:** Bluetooth and BLE gateway are available for inclusion purposes, which may be useful during the setup process.
- **Zigbee Connectivity:** Zigbee is available for inclusion purposes, which may be useful during the setup process.
- **Integration with Smart Home Platforms:** You can integrate the Shelly 1PM Gen4 with popular smart home platforms, including Google, Alexa, and Samsung SmartThings. This enables voice control and automation capabilities through these platforms.
- **Smart Switch with Power Measurement:** Acts as a smart switch with the added capability of measuring power consumption, allowing you to monitor the energy usage of connected appliances.
- **Compact Design:** Designed as a small form factor switch, making it suitable for retrofitting into standard electrical wall boxes, behind power sockets, light switches, or other confined spaces.
- **Remote Control:** Enables remote control of electric appliances via a mobile phone, tablet, PC, or home automation system.
- **Local and Cloud Control:** Can function independently in a local Wi-Fi network and can also be operated through cloud home automation services.
- **Improved Processor:** Upgraded with an improved processor and support for Zigbee connectivity.
- **Remote Access:** Allows remote access, control, and monitoring from any location with internet connectivity, provided the device is connected to a Wi-Fi router and the internet.
- **Embedded Web Interface:** Features an embedded web interface for monitoring, control, and adjustment of settings.
- **Wireless Connectivity:** The device supports Wi-Fi (802.11 b/g/n/ax) and Bluetooth 5.0 protocols with specified indoor and outdoor range capabilities.
- **BLE Gateway:** Bridge between your Shelly BLU devices and the wider Shelly ecosystem. It receives Bluetooth signals and sends them to the cloud or locally to another non-bluetooth device.
- **Wi-Fi Range extender for IoT devices:** A Wi-Fi extender is employed to expand the reach of your Wi-Fi network by receiving your current Wi-Fi signal, enhancing its strength, and then transmitting the enhanced signal over a wider area.
- **Zigbee Range extender for IoT devices:** A Zigbee extender is employed to expand the reach of your Zigbee network by receiving your Zigbee signal, enhancing its strength, and then transmitting the enhanced signal over a wider area.
- **Scripting:** <https://shelly-api-docs.shelly.cloud/gen2/Scripts/ShellyScriptLanguageFeatures/>
- **Wide range of integrations:** The device can be integrated with 3rd party home systems, documented HTTP API, MQTT(s), Web Hooks over HTTP and HTTPS, UDP
- **Schedules:** Allows scheduling of complex operations to be executed in predefined time window. Users can specify time windows based on date, time of day, weekdays, hours, minutes and seconds.
- **Virtual Components:** <https://shelly-api-docs.shelly.cloud/gen2/DynamicComponents/Virtual/>
- **KNX net/IP support:** <https://shelly-api-docs.shelly.cloud/gen2/Integrations/KNX/>

Use cases

- **Appliance Control:** Use it to remotely control and automate the operation of various electric appliances such as lights, fans, or other devices.
- **Power Monitoring:** Monitor the power consumption of connected appliances in real-time. This is useful for understanding energy usage patterns and promoting energy efficiency.
- **Home Automation:** Integrate the Shelly 1PM Gen4 into your home automation system to create custom scenes and schedules for your devices.



Shelly 1PM Gen4 datasheet

- **Energy Efficiency:** Leverage the power measurement feature to identify energy-hungry appliances and make informed decisions to improve overall energy efficiency in your home.
- **Remote Monitoring:** Keep an eye on your devices even when you're away from home. The remote access feature allows you to monitor and control connected appliances from anywhere with internet connectivity.

Home Automation Use Cases

Lighting Control with Power Monitoring

- Remotely control lights and monitor their power consumption.
- Detect if a bulb has failed by observing power usage.
- Identify which rooms have high lighting energy usage.

Appliance Monitoring and Automation

- Automate and track usage of high-load appliances (e.g., oven, dishwasher, washing machine).
- Use power data to trigger automations (e.g., notification when laundry is done).
- Schedule devices to run during off-peak energy hours.

Heater and Boiler Control

- Turn on/off electric water heaters or room heaters (Max. switching current: 16A).
- Monitor energy consumption to understand heating costs.
- Automate based on temperature or time-of-day schedules.

Overload Protection

- Protect connected appliances by setting maximum power thresholds.
- Automatically shut off if power draw exceeds limits.

Commercial & Retail Applications

Energy Optimization in Offices

- Track and optimize energy use for shared equipment (printers, coffee machines).
- Automate equipment shut-off after working hours.

Lighting Zones with Energy Analytics

- Group lighting by zones and analyze energy patterns for cost-saving.

Preventive Maintenance

- Detect abnormal power consumption trends to anticipate faults in machines or fixtures.

Industrial & Utility Applications

Motor or Pump Control with Monitoring

- Control irrigation or circulation pumps (Max. switching current: 16A).



Shelly 1PM Gen4 datasheet

- Monitor energy use to detect if a motor is under- or over-performing (Max. switching current: 16A).

Solar/Off-Grid Power Use Tracking

- Monitor the load on circuits fed by inverters or battery backups (Max. switching current: 16A).
- Optimize load based on solar production or battery capacity (Max. switching current: 16A).

Main applications

- Residential
- MDU (Multi Dwelling Units - apartments, condominiums, hotels, etc.)
- Light commercial (small office buildings, small retail/restaurant/gas station, etc.)
- Government/municipal
- University/college

Integrations

Amazon Alexa supported capabilities

- [Turn On/Off](#)

Google Smart Home supported traits

- [Turn On/Off](#)

Samsung SmartThings supported capabilities

- [Turn On/Off](#)

Simplified internal schematics

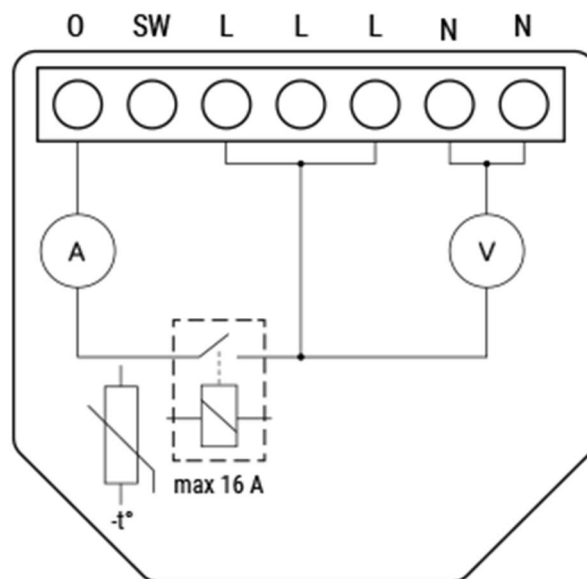

Device electrical interfaces



Shelly 1PM Gen4 datasheet

Inputs

- 1 switch/button input on screw terminal: SW
- 5 power supply inputs on screw terminals: 2 N (+) and 3 L (L)

Outputs

- 1 relay output with power measurement on screw terminal: O

Add-on interface

- Shelly proprietary serial interface

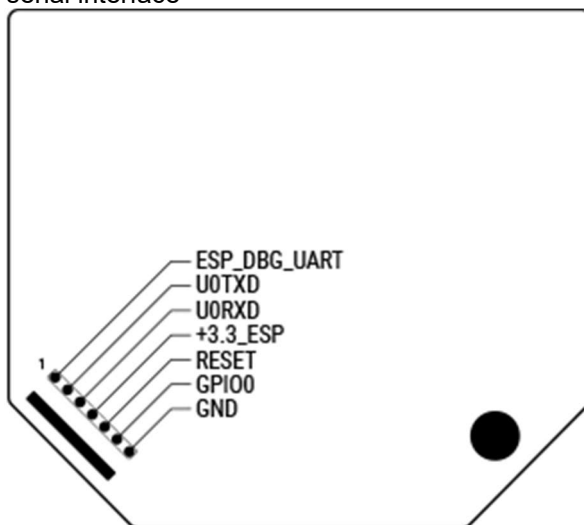

⚠CAUTION! High voltage on the add-on interface when the Device is powered!

Connectivity

- Wi-Fi
- Bluetooth
- Zigbee
- Matter

Safety function

- Overheating protection
- Overvoltage protection
- Overcurrent protection
- Overpower protection

Supported load types

- Resistive (incandescent bulbs, heating appliances)
- Capacitive (capacitor banks, electronic equipment, motor starting capacitors)
- Inductive with RC Snubber (LED light drivers, transformers, fans, refrigerators, air-conditioners, washing machines, tumble dryers)



Shelly 1PM Gen4 datasheet

User interface

Inputs

- One (Control) button
 - Press and hold for 5 seconds to enable Device access point and Bluetooth connection.
 - Press and hold for 10 seconds to factory reset the Device.
 - Press the button 5 times to switch the Device from Matter (default) to Zigbee profile. The Device enters inclusion mode for 3 minutes. Include the Device following the instructions of your Zigbee home automation system.
 - Press the button 3 times to restart the inclusion mode for another 3 minutes if you missed the previous 3-minute window.

Outputs

- LED (monocolor) indication
 - AP (Access Point) enabled and Wi-Fi disabled:
1 second ON / 1 second OFF
 - Wi-Fi enabled, but not connected to a Wi-Fi network:
1 second ON / 3 seconds OFF
 - Connected to a Wi-Fi network:
Constantly ON
 - Cloud is enabled, but not connected:
1 second ON / 5 seconds OFF
 - Connected to Shelly Cloud:
Constantly ON
 - OTA (Over the Air Update):
½ sec ON / ½ second OFF
 - Button pressed and held for 5 seconds:
½ second ON / ½ second OFF
 - Button pressed and held for 10 seconds:
¼ second ON / ¼ second OFF

The list above starts with the initial device status and the lowest priority. Every next state cancels the previous one.

Specifications

Quantity	Value
Physical	
Size (HxWxD):	37x42x16 mm / 1.46x1.65x0.63 inch
Weight:	27 g / 0.95 oz
Screw terminals max torque:	0.4 Nm / 3.5 lbin
Conductor cross section:	0.5 to 4 mm ² / 20 to 11 AWG (solid, stranded, and bootlace ferrules)
Conductor stripped length:	6 to 7 mm / 0.24 to 0.28 in
Mounting:	Wall console



Shelly 1PM Gen4 datasheet

Shell material:	Plastic
Shell color:	Red
Terminals color:	Grey (Mouse Grey)
Environmental	
Ambient working temperature:	-20 °C to 40 °C / -5 °F to 105 °F
Humidity:	30 % to 70 % RH
Max. altitude:	2000 m / 6562 ft
Electrical	
Power supply:	<ul style="list-style-type: none">• 110-240 V~• 24-30 V=
Power consumption:	< 1 W
Neutral not needed:	No
External protection:	Cable protection switch in accordance with EN60898-1 (tripping characteristic B or C, max. 16 A rated current, min. 6 kA interrupting rating, energy limiting class 3)
Output circuits ratings	
Max. switching voltage:	<ul style="list-style-type: none">• 240 V~• 30 V=
Max. switching current:	<ul style="list-style-type: none">• 16A (240 V~)• 10A (30 V=)
Sensors, meters	
Voltmeter (AC):	Yes
Ammeter (AC):	Yes
Internal-temperature sensor:	Yes
Radio	
Wi-Fi	
Protocol:	802.11 b/g/n/ax
RF band:	2412 - 2472 MHz
Max. RF power:	< 20 dBm
Range:	Up to 30 m / 100 ft indoors and 50 m / 160 ft outdoors (Depends on local conditions)
Bluetooth	
Protocol:	5.0
RF band:	2402 - 2480 MHz



Shelly 1PM Gen4 datasheet

Max. RF power:	< 4 dBm
Range:	Up to 10 m / 33 ft indoors and 30 m / 100 ft outdoors (Depends on local conditions)
Zigbee	
Protocol:	802.15.4
Zigbee repeater:	Yes
RF bands:	2400 to 2483.5 MHz
Max. RF power:	< 20 dBm
Range:	Up to 100 m / 328 ft indoors and 300 meters / 984 ft outdoors (Depends on local conditions)
Microcontroller unit	
CPU:	ESP-Shelly-C68F
Flash:	8MB
Firmware capabilities	
Schedules:	20
Webhooks (URL actions):	20 with 5 URLs per hook
Scripting:	Yes
MQTT:	Yes

Basic wiring diagrams

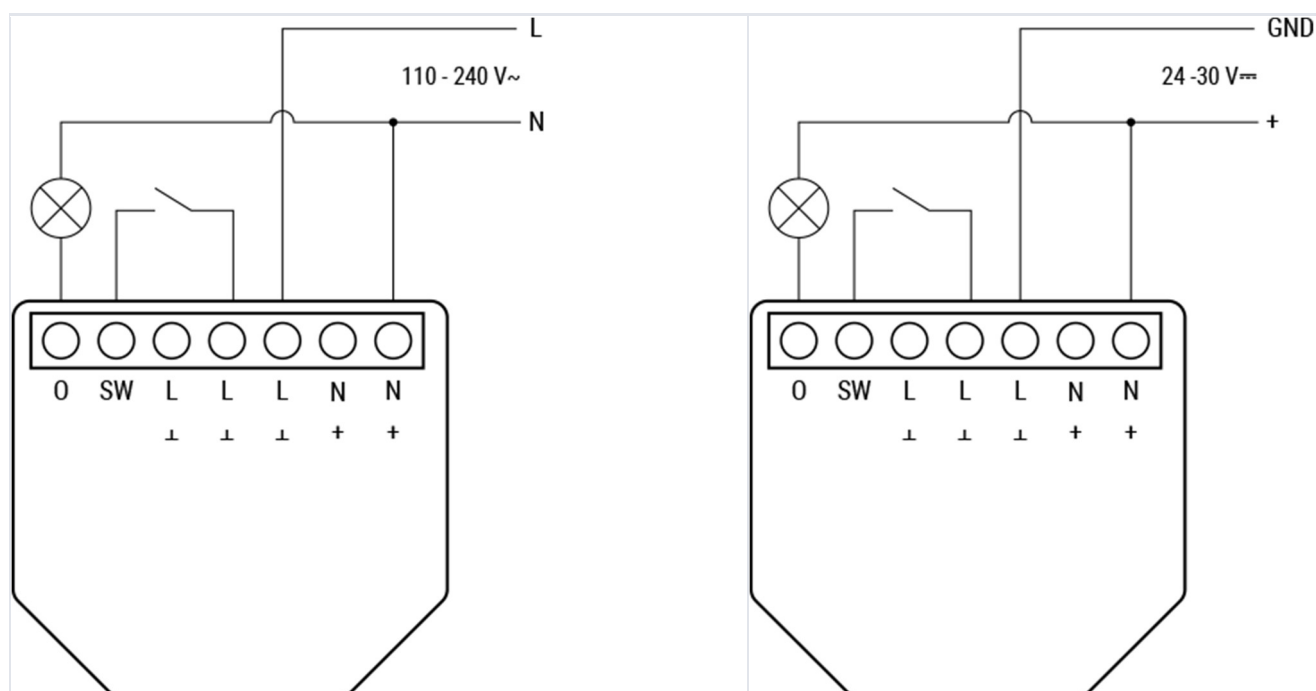



Shelly 1PM Gen4 datasheet

110-240 V~ power supply

24-30 V= power supply

Legend

Enlarges the table by opening it in a full screen dialogOpen

O	Load circuit output terminal	L	Live wire (110-240 V~)
SW	Switch (controlling O) input terminal	+	24-30V = positive wire
L	Live terminal (110-240 V~)	N	Neutral wire
N	Neutral terminal		
+	24-30 V= positive terminal		
⊥	24-30V= ground terminal		

Shelly Smart Control

- [Adding the device to the Shelly Smart Control](#)

Shelly Web user interface

- [Shelly 1PM Gen4 Web user interface guide](#)

Components and APIs

- [This device](#)
- [All Shelly devices and services](#)

Compliance

- [Shelly 1PM Gen4 multilingual EU declaration of conformity 269 2026-03-13.pdf](#)
- [Shelly 1PM Gen4 UK PSTI ACT statement of compliance 269 2026-03-13.pdf](#)
- [Shelly 1PM Gen4 UKCA declaration of conformity 269 2026-03-13.pdf](#)